

Piling hammer CG240

These large-capacity hammers are capable of driving piles with an ultimate load bearing of up to 23,700kN.

- Total control of hammer stroke and blow rate
- Allows precise matching of energy to suit the pile driving requirements
- Quick and easy dolly changing
- Cylinder and drop-weight connection with shock absorber is easily accessible
- Economical, low hydraulic power design
- Available with BSP-TEX Hydropacks for optimum hammer performance
- Suitable for driving raked (batter) piles

CG specifications

CG240

| | |
|-----------------------------------|----------|
| Dropweight mass (kg) | 16000 |
| Hammer energy (kN.m) | 240 |
| Max equivalent stroke (m) | 1.5 |
| Operating pressure (bar) | 260 |
| Hyd. oil flow required (L/min) | 420 |
| Blow rate at rated energy (bpm) | 34 |
| Basic hammer length (m) | 6930 |
| Basic hammer weight (kg) | 21700 |
| Compatible power pack - Stage III | HP252 |
| Compatible power pack - stage V | HP260 |
| Operating mode | FS/PR |
| Pile type | TH/CW/CP |
| Maximum pile size (mm) | 2500 |
| Power source | PP |
| Max pile bearing capacity (kN) | 19000 |

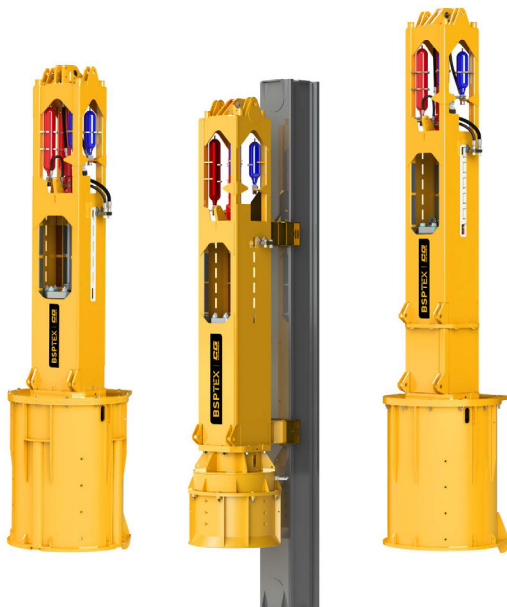

Pile sleeve assembly for 60" piles - Model CG180-240

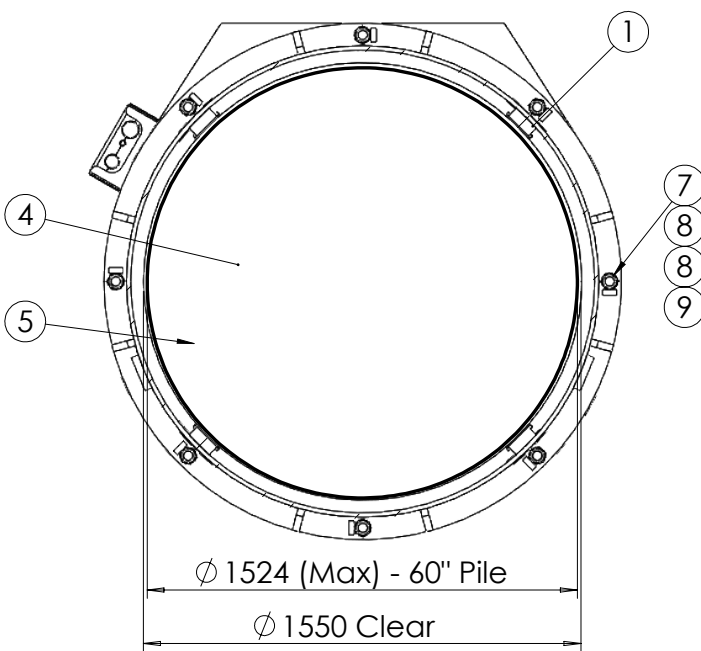
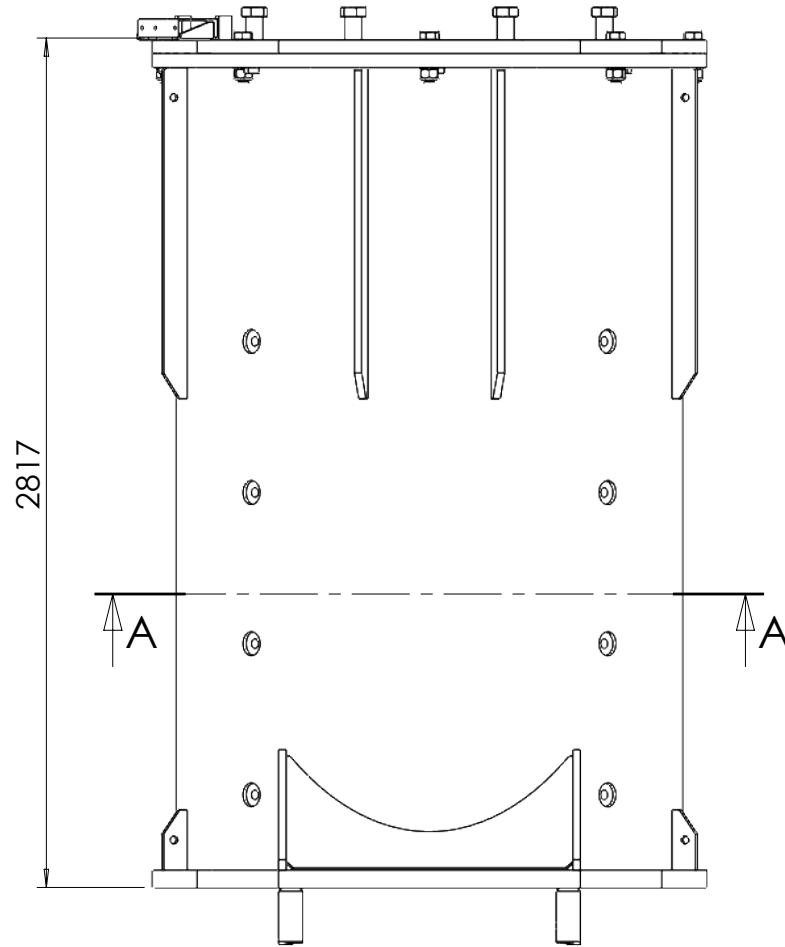

SECTION A-A
SCALE 1 : 30

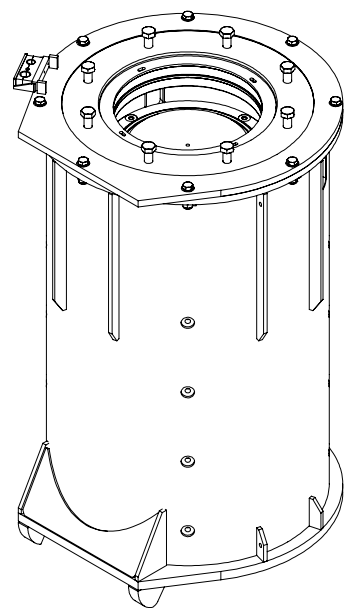



ENGINEERING
PARTS LIST

TITLE:

PILE SLEEVE ASSEMBLY FOR 60" PILES

REVISION

LIST No. 4421 1724

Model CG180-240

Job Ref. -

Serial No.

bsp INTERNATIONAL FOUNDATIONS Ltd.

| Item | Part No. | Description | Default/ QTY | Remarks |
|------|-----------|---------------------------------------|-----------------|---------|
| 1 | 4421 1723 | Pile Sleeve for 60" Piles | 1 | |
| 2 | 4421 1722 | Cage Bottom Adaptor for 60" dia Piles | 1 | |
| 3 | 4421 1015 | UPPER VIBRATION DAMPER (blue) | 1 | |
| 4 | 4421 1090 | LOWER VIBRATION DAMPER (orange) | 1 | |
| 5 | 4421 1042 | M48 x 180 Hex Head Bolt | 8 | |
| 6 | 0705 2060 | M36 x 140 | 8 | |
| 7 | 0714 0164 | M48 Nyloc Nut | 8 | |
| 8 | 0714 0162 | M36 Nyloc Nut | 8 | |
| 9 | 0780 0160 | M36 Nord Lock - NL | 16 | |

FOR REFERENCE

| Item | Part No. | Description | Default/ QTY | Remarks |
|------|-----------|--------------------------------|-----------------|---------|
| 20 | 4421 1721 | Drive Cap for 60" Piles (1600) | 1 | |
| 21 | 4421 0583 | Plastic Dolley | 1 | |

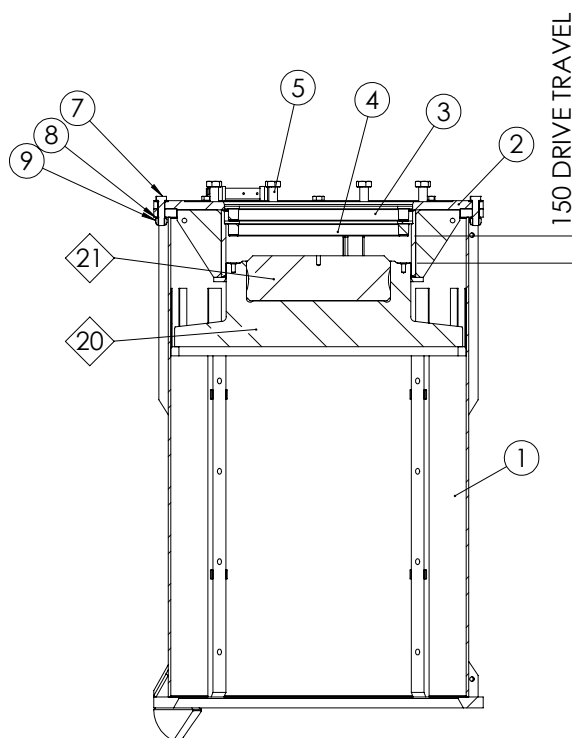

SECTION B-B
SCALE 1 : 40

Name SJW
Date 06/08/2016
Signed
Weight (kg). 7376.46

Sheet 2 of 2